

←—————→
Introduction

LASER stands for light Amplification by Stimulated Emission of Radiation. The theoretical basis for the development of laser was provided by Albert Einstein in 1917. In 1960, the first laser device was developed by T.H. Mainmann.

1. Definitions

Stimulated absorption (or) Absorption

Let E_1 and E_2 be the energies of ground and excited states of an atom. Suppose, if a photon of energy $E_2 - E_1 = h\nu$ interacts with an atom present in the ground state, the atom gets excitation from ground state E_1 to excited state E_2 . This process is called stimulated absorption

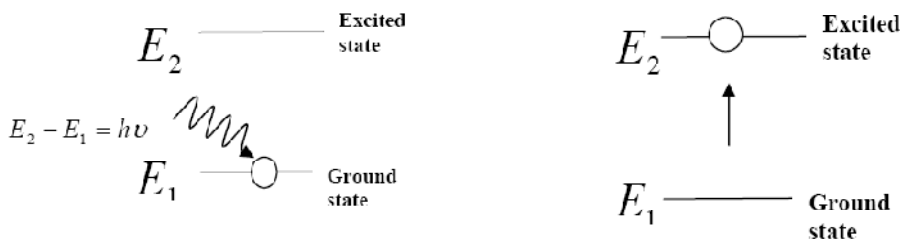

Stimulated absorption rate depends upon the number of atoms available in the lowest energy state as well as the energy density photons.

Stimulated absorption rate \propto number of atoms in the ground state
 \propto Density of photons

Spontaneous emission

Spontaneous emission was postulated by Bohr. Let E_1 and E_2 be the energies of ground and excited states of an atom. Suppose, if a photon of energy $E_2 - E_1 = h\nu$ interacts with an atom present in the ground state, the atom gets excitation from ground state E_1 to excited state E_2 . The excited atom does not stay in a long time in the excited state. The excited atom gets de-excitation after its life time by emitting a photon of energy $E_2 - E_1 = h\nu$. This process is called spontaneous emission.

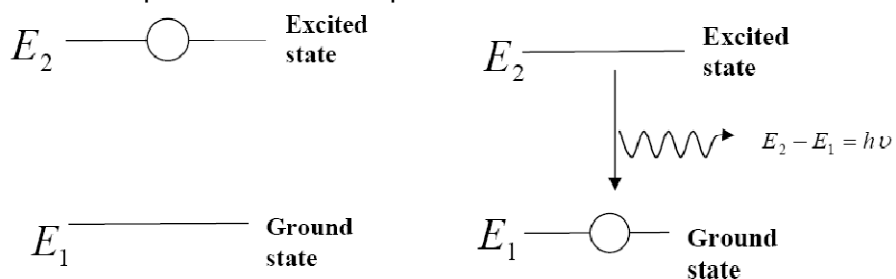

The spontaneous emission rate depends up on the number of atoms present in the excited state.

Spontaneous emission rate \propto number of atoms in the excited state

Stimulated emission

Stimulated emission was postulated by Einstein. Let E_1 and E_2 be the energies of ground and excited states of an atom. Suppose, if a photon of energy $E_2 - E_1 = h\nu$ interacts with an atom present in the ground state, the atom gets excitation from ground state E_1 to excited state E_2 . Let, a photon of energy $E_2 - E_1 = h\nu$ interacts with the excited atom within their life time; the atom gets de-excitation to ground state by emitting of another photon. These photons have same phase and it follows coherence. This phenomenon is called stimulated emission.

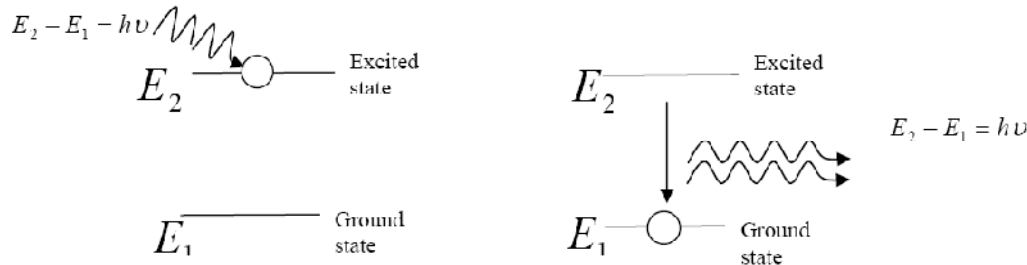

Stimulated emission rate depends upon the number of atoms available in the excited state as well as the energy density of photons.

Stimulated emission rate \propto number of atoms in the excited state
 \propto Density of photons

Spontaneous and Stimulated emission

Spontaneous emission	Stimulated emission
1. The spontaneous emission was postulated by Bohr	1. The stimulated emission was postulated by Einstein
2. Additional photons are not required in spontaneous emission	2. Additional photons are required in stimulated emission
3. One photon is emitted in spontaneous emission	3. Two photons are emitted in stimulated emission
4. The emitted radiation is poly-monochromatic	4. The emitted radiation is monochromatic
5. The emitted radiation is Incoherent	5. The emitted radiation is Coherent
6. The emitted radiation is less intense	6. The emitted radiation is high intense
7. The emitted radiation have less directionality Example: light from sodium or mercury lamp	7. The emitted radiation have high directionality Example: light from laser source.

2. Characteristic of laser radiation

The laser light exhibits some peculiar properties than compare with the convectional light. Those are

1. Highly directionality
2. Highly monochromatic
3. Highly intense
4. Highly coherence

The light ray coming ordinary light source travels in all directions, but laser light travels in single direction.

For example the light emitted from torch light spreads 1km distance it spreads 1 km distance. But the laser light spreads a few centimeters distance even it travels lacks of kilometer distance.

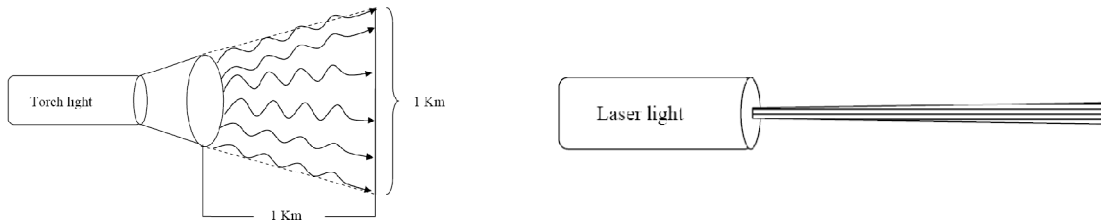

The directionality of laser beam is expressed in terms of divergence

$$\Delta\theta = \frac{r_2 - r_1}{D_2 - D_1}$$

Where r_2 and r_1 are the radii of laser beam spots at distances of D_2 and D_1 respectively from laser source.

2. Highly monochromatic

The laser light is more monochromatic than that of a conventional light source. This may be due to the stimulated characteristic of laser light. The band width of conventional monochromatic light source is 1000\AA . But the band width of ordinary light source is 10\AA . For high sensitive laser source is 10^{-8}\AA .

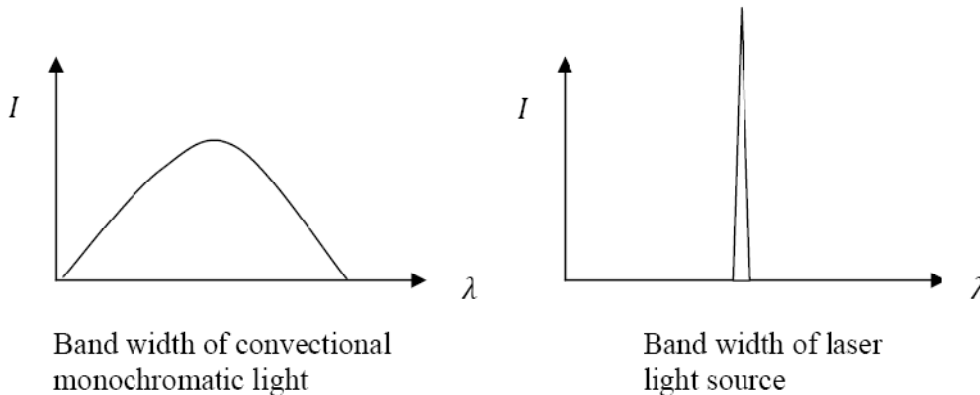

3. Highly intense

Laser light is highly intense than the conventional light. An one milliwatt He-Ne laser is highly intense than the sun intensity. This is because of coherence and directionality of laser. Suppose when two photons each of amplitude a are in phase with other, then young's principle of superposition, the resultant amplitude of two photons is $2a$ and the intensity is $4a^2$. Since in laser many number of photons are in phase with each other, the amplitude of the resulting wave becomes na and hence the intensity of laser is proportional to n^2a^2 . So 1mW He-Ne laser is highly intense than the sun.

4. Highly coherence

Definition:-

A predictable correlation of the amplitude and phase at any one point with other point is called coherence.

In case of conventional light, the property of coherence exhibits between a source and its virtual source whereas in case of laser the property coherence exists between any

There are two types of coherence

- i) Temporal coherence
- ii) Spatial coherence.

Temporal coherence (or longitudinal coherence):-

The predictable correlation of amplitude and phase at one point on the wave train w.r.t another point on the same wave train, then the wave is said to be temporal coherence

To understand this, let us consider two points P_1 and P_2 on the same wave train, which is continuous as in shown in figure (1). Suppose the phase and amplitude at any one point is known, then we can easily calculate the amplitude and phase for any other point on the same wave train by using the wave equation

$$y = a \sin\left(\frac{2\pi}{\lambda}(ct - x)\right)$$

Where 'a' is the amplitude of the wave and 'x' is the displacement of the wave at any instant of time 't'.



Spatial coherence (or transverse coherence)

The predictable correlation of amplitude and phase at one point on the wave train w.r.t another point on a second wave, then the waves are said to be spatial coherence (or transverse coherence)

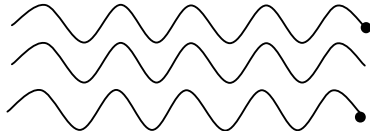

Two waves are said to be coherent, the waves must have

3. Population inversion

Definition

The number of atoms present in the excited (or higher) state is greater than the number of atoms present in the ground state (or lower) state is called population inversion.

Or

The population present in the excited (or higher) state is greater than the population present in the ground state (or lower) state is called population inversion.

Let us consider two level energy system of energies E_1 and E_2 as shown in figure. Let N_1 and N_2 be the populations (means number of atoms per unit volume) of energy levels E_1 and E_2 .

According to Boltzmann's distribution the population of an energy level E, at temperature T is given by

$$N_i = N_0 e^{\left(\frac{-E_i}{KT}\right)}$$

Where N_0 is the population of the lower level or ground state and k is the Boltzmann's constant. From the above relation, the population of energy levels E_1 and E_2 are

$$N_1 = N_0 e^{\left(\frac{-E_1}{KT}\right)}$$

$$N_2 = N_0 e^{\left(\frac{-E_2}{KT}\right)}$$

At ordinary conditions $N_1 > N_2$, i.e., the population in the ground or lower state is always greater than the population in the excited or higher states. The stage of making, population of higher energy level is greater than the population of lower energy level is called population inversion i.e., $N_2 > N_1$.

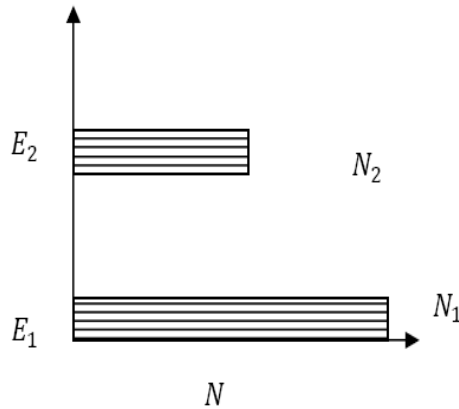

At normal conditions $N_1 > N_2$

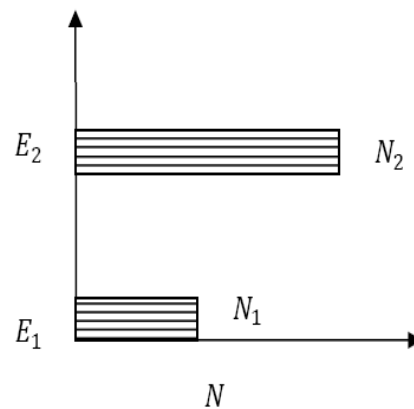

After population inversion is achieved $N_2 > N_1$

Consider a three energy level system with energies E_1, E_2 and E_3 of populations N_1, N_2 , and N_3 . At normal conditions, $E_1 < E_2 < E_3$ and $N_1 < N_2 < N_3$. In the ground state E_1 the life time of atom is more and the life time of atom in the excited state E_3 is 10^{-8} seconds. But in the intermediate state E_2 the atom has more life time (10^{-3} seconds). So it is called metastable state.

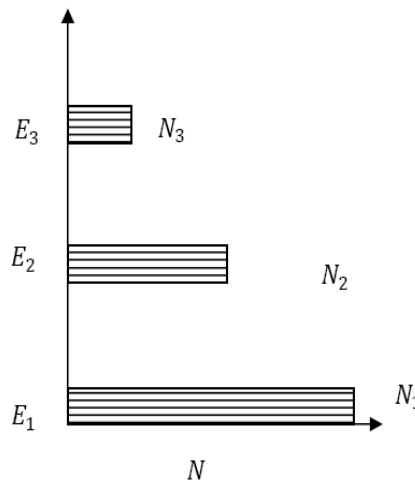

At normal conditions $N_1 > N_2$

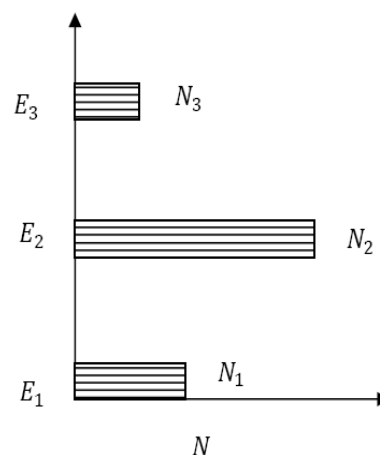

After population inversion is achieved $N_2 > N_1$

When a suitable energy is supplied to the system, atoms get excited into E_3 . After their lifetime the atoms are transit to E_2 . Due to more lifetime of an atom in state E_2 , the atoms stay for longer time than compare with the state E_3 . Due to the accumulation of atoms in E_2 , the population inversion is established in between the E_2 and E_1 states.

4. Einstein coefficients

Let N_1 be the number of atoms per unit volume with energy E_1 and N_2 be the number of atoms per unit volume with energy E_2 . Let 'n' be the number of photons per unit volume at frequency ' ν ' such that $E_1 - E_2 = h\nu$. Then, the energy density of photons $\rho(\nu) = nh\nu$. When these photons interact with atoms, both upward (absorption) and downward (emission) transition occurs. At the equilibrium the upward transitions must be equal downward transitions.

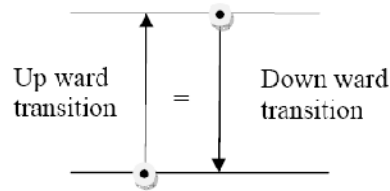

Upward transition

Stimulated absorption rate depends upon the number of atoms available in the lowest energy state as well as the energy density photons.

$$\begin{aligned} \text{Stimulated absorption rate} &\propto N_1 \\ &\propto \rho(\nu) \\ &= B_{12}N_1 \rho(\nu) \end{aligned}$$

Where B_{12} is the Einstein coefficient of stimulated absorption.

Downward transition

The spontaneous emission rate depends up on the number of atoms present in the excited state.

$$\begin{aligned} \text{Spontaneous emission rate} &\propto N_2 \\ &= A_{21}N_2 \end{aligned}$$

Where A_{21} is the Einstein coefficient of spontaneous emission.

Stimulated emission rate depends upon the number of atoms available in the excited state as well as the energy density of photons.

$$\begin{aligned} \text{Stimulated emission rate} &\propto N_2 \\ &\propto \rho(\nu) \\ &= B_{21}N_2 \rho(\nu) \end{aligned}$$

Where B_{21} is the Einstein coefficient of stimulated emission.

If the system is in equilibrium the upward transitions must be equal downward transitions.

$$B_{12}N_1\rho(\nu) = A_{21}N_2 + B_{21}N_2\rho(\nu)$$

$$B_{12}N_1\rho(\nu) - B_{21}N_2\rho(\nu) = A_{21}N_2$$

$$\rho(\nu)(B_{12}N_1 - B_{21}N_2) = A_{21}N_2$$

$$\rho(\nu) = \frac{A_{21}N_2}{(B_{12}N_1 - B_{21}N_2)}$$

Divide with $B_{21}N_2$ in numerator and denominator in right side of the above equation

$$\rho(\nu) = \frac{A_{21}N_2/B_{21}N_2}{(B_{12}N_1 - B_{21}N_2)/B_{21}N_2} = \frac{A_{21}/B_{21}}{\frac{B_{12}N_1}{B_{21}N_2} - 1} \quad (1)$$

$$\rho(\nu) = \frac{A_{21}N_2/B_{21}N_2}{(B_{12}N_1 - B_{21}N_2)/B_{21}N_2} = \frac{A_{21}/B_{21}}{\frac{B_{12}}{B_{21}}e^{(\epsilon_2 - \epsilon_1)/KT} - 1} \quad (2)$$

From Maxwell Boltzmann distribution law

$$\frac{N_1}{N_2} = e^{(\varepsilon_2 - \varepsilon_1)/kT}$$

From Planck's law, the radiation density

$$\rho(\nu) = \frac{8\pi h\nu^3 / C^3}{e^{(\varepsilon_2 - \varepsilon_1)/kT} - 1} \quad (3)$$

Comparing the two equations (2) and (3)

$$\frac{A_{21}}{B_{21}} = \frac{8\pi h\nu^3}{C^3} \quad \text{and} \quad \frac{B_{12}}{B_{21}} = 1$$

The above relations referred to as Einstein relations

From the above equation for non degenerate energy levels the stimulated emission rate is equal to the stimulated absorption rate at the equilibrium condition.

$$B_{21} = B_{12}$$

5. Pumping mechanisms (or techniques) of population inversion

A system in which population inversion is achieved is called as an active system. The method of raising the particles from lower energy state to higher energy state is called pumping. (Or the process of achieving of population inversion is called pumping). This can be done by number of ways. The most commonly used pumping methods are

- I. Optical pumping
- II. Electrical discharge pumping
- III. Chemical pumping
- IV. Injection current pumping

Optical pumping

Optical pumping is used in solid laser. Xenon flash tubes are used for optical pumping. Since these materials have very broad band absorption, sufficient amount of energy is absorbed from the emission band of flash lamp and population inversion is created. Examples of optically pumped lasers are ruby, Nd: YAG Laser ($Y_3Al_5G_{12}$) (Neodymium: Yttrium Aluminum Garnet), Nd: Glass Laser

Electrical discharge pumping

Electrical discharge pumping is used in gas lasers. Since gas lasers have very narrow absorption band pumping them any flash lamp is not possible. Examples of Electrical discharge pumped lasers are He-Ne laser, CO₂ laser, argon-ion laser, etc

Chemical pumping

Chemical reaction may also result in excitation and hence creation of population inversion in few systems. Examples of such systems are HF and DF lasers.

Injection current pumping

In semiconductors, injection of current through the junction results in creates of population inversion among the minority charge carriers. Examples of such systems are InP and GaAs.

Different Types of lasers

On the basis of active medium used in the laser systems, lasers are classified into several types

- | | |
|-------------------------|--|
| I. Solid lasers | : Ruby laser, Nd:YAG laser, Nd:Glass |
| II. Liquid lasers | : Europium Chelate laser, SeOCl_2 |
| III. Gas lasers | : CO_2 , He-Ne, Argon-Ion Laser |
| IV. Dye lasers | : Rhodamine 6G |
| V. Semiconductor lasers | : InP, GaAs. |

6. Ruby laser

Ruby laser is a three level solid state laser and was constructed by Mainmann in 1960. Ruby ($\text{Al}_2\text{O}_3 + \text{Cr}_2\text{O}_3$) is a crystal of Aluminium oxide, in which 0.05% of Al^{+3} ions are replaced by the Cr^{+3} ions. The colour of the rod is pink. The active medium in the ruby rod is Cr^{+3} ions.

Construction

In ruby laser 4cm length and 5mm diameter rod is generally used. Both the ends of the rods are highly polished and made strictly parallel. The ends are silvered in such a way, one becomes partially reflected and the other end fully reflected. The ruby rod is surrounded by xenon flash tube, which provides the pumping light to excite the chromium ions in to upper energy levels.

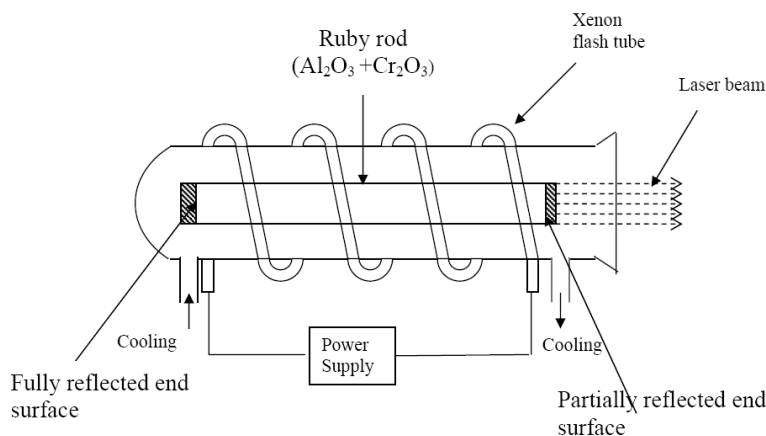

Xenon flash tube emits thousands joules of energy in few milli seconds, but only a part of that energy is utilized by the chromium ions while the rest energy heats up the apparatus. A cooling arrangement is provided to keep the experimental set up at normal temperatures

Working

The energy level diagram of chromium ions is shown in figure.

The chromium ions get excitation into higher energy levels by absorbing of 5600\AA of wave length radiation. The excited chromium ions stay in the level H for short interval of time (10^{-8} Sec). After their life time most of the chromium ions are de-excited from H to G and a few chromium ions are de-excited from H to M.

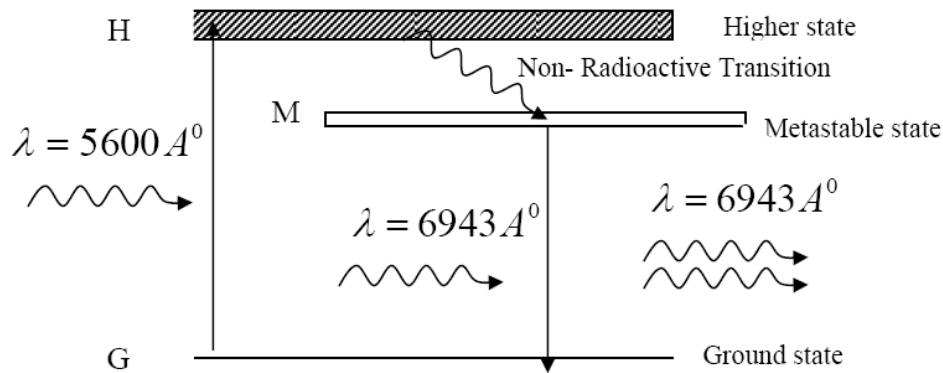

The transition between H and M is non-radioactive transition i.e. the chromium ions give their energy to the lattice in the form of heat. In the Metastable state the life time of chromium ions is 10^{-3} sec. The life time of chromium ions in the Metastable state is 10^5 times greater than the life time of chromium ions in higher state.

Due to the continuous working of flash lamp, the chromium ions are excited to higher state H and returned to M level. After few milli seconds the level M is more populated than the level G and hence the desired population inversion is achieved. The state of population inversion is not a stable one. The process of spontaneous transition is very high. When the excited chromium ion passes spontaneously from H to M it emits one photon of wave length 6943 \AA . The photon reflects back and forth by the silver ends and until it stimulates an excited chromium ion in M state and it to emit fresh photon in phase with the earlier photon. The process is repeated again and again until the laser beam intensity is reached to a sufficient value. When the photon beam becomes sufficient intense, it emerges through the partially silvered end of the rod. The wave length 6943 \AA is in the red region of the visible spectrum.

Draw backs of ruby laser

- The laser requires high pumping power
- The efficiency of ruby laser is very small
- It is a pulse laser

Uses of ruby laser

1. Ruby lasers are in optical photography
2. Ruby lasers can be used for measurement of plasma properties such as electron density and temperature.
3. Ruby lasers are used to remove the melanin of the skin.
4. Ruby laser can be used for recording of holograms.

7. He-Ne Laser

Ruby laser is a pulse laser, even it have high intense out put. For continuous laser beam gas lasers are used. Using gas lasers, we can achieve highly coherence, high directionality and high monochromacity beam. The out put power of the gas laser is generally in few milli watts. The first He-Ne gas laser was fabricated by Ali Javan and others

Construction

In He-Ne gas laser, the He and Ne gases are taken in the ratio 10:1 in the discharge tube. Two reflecting mirrors are fixed on either ends of the discharge tube, in that, one is partially reflecting and the other is fully reflecting. In He-Ne laser 80cm length and 1cm diameter discharge is generally used. The out power of these lasers depends on the length of the discharge tube and pressure of the gas mixture.

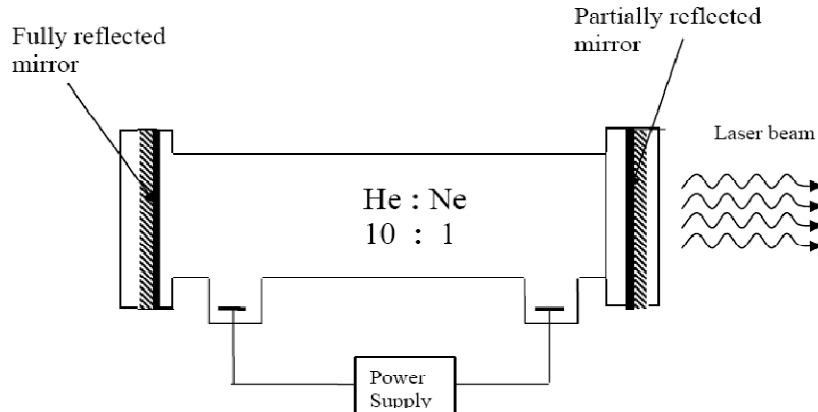

Working

When the electric discharge is passing through the gas mixture, the electrons accelerated towards the positive electrode. During their passage, they collide with He atoms and excite them into higher levels. F_2 and F_3 form F_1 . In higher levels F_2 and F_3 , the life time of He atoms is more. So there is a maximum possibility of energy transfer between He and Ne atoms through atomic collisions. When He atoms present in the levels F_2 and F_3 collide with Ne atoms present ground state E_1 , the Ne atoms gets excitation into higher levels E_4 and E_6 .

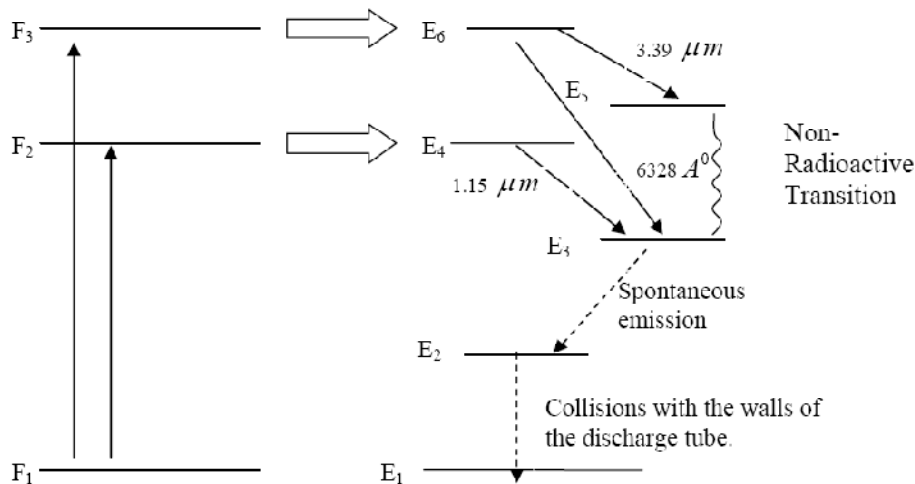

Due to the continuous excitation of Ne atoms, we can achieve the population inversion between the higher levels E_4 (E_6) and lower levels E_3 (E_5). The various transitions $E_6 \rightarrow E_5$, $E_4 \rightarrow E_3$ and $E_6 \rightarrow E_3$ leads to the emission of wavelengths $3.39\mu m$, $1.15\mu m$ and 6328\AA . The first two corresponding to the infrared region while the last wavelength is corresponding to the visible region. The Ne atoms present in the E_3 level are de-excited into E_2 level, by spontaneously emitting a photon of around wavelength 6000\AA . When a narrow discharge tube is used, the Ne atoms present in the level E_2 collide with the walls of the tube and get de-excited to ground level E_1 .

8. Applications of lasers

Due to high intensity, high monochromaticity and high directionality of lasers, they are widely used in various fields like

1. communication
2. computers
3. chemistry
4. photography
5. industry
6. medicine
7. military
8. scientific research

1. communication

In case of optical communication semiconductors laser diodes are used as optical sources and its band width is (10^{14} Hz) is very high compared to the radio and microwave communications.

- More channels can be sent simultaneously
- Signal cannot be tapped
- As the band width is large, more data can be sent.
- A laser is highly directional and less divergence, hence it has greater potential use in space crafts and submarines.

2. Computers

- In LAN (local area network), data can be transferred from memory storage of one computer to other computer using laser for short time.
- Lasers are used in CD-ROMS during recording and reading the data.

3. Chemistry

- Lasers are used in molecular structure identification
- Lasers are also used to accelerate some chemical reactions.
- Using lasers, new chemical compounds can be created by breaking bonds between atoms and molecules.

4. Photography

- Lasers can be used to get 3-D lens less photography.
- Lasers are also used in the construction of holograms.

5. Industry

- Lasers can be used to blast holes in diamonds and hard steel
- Lasers are also used as a source of intense heat
- Carbon dioxide laser is used for cutting drilling of metals and nonmetals, such as ceramics plastics glass etc.
- High power lasers are used to weld or melt any material.
- Lasers are also used to cut teeth in saws and test the quality of fabric.

6. Medicine

- Pulsed neodymium laser is employed in the treatment of liver cancer.
- Argon and carbon dioxide lasers are used in the treatment of liver and lungs.
- Lasers used in the treatment of Glaucoma.

-
- Lasers used in endoscopy to scan the inner parts of the stomach.
 - Lasers used in the elimination of moles and tumors which are developing in the skin tissue.

7. Military

- Lasers can be used as a war weapon.
- High energy lasers are used to destroy the enemy air-crofts and missiles.
- Lasers can be used in the detection and ranging likes RADAR.

8. Scientific research

- Lasers are used in the field of 3D-photography
- Lasers used in Recording and reconstruction of hologram.
- Lasers are employed to create plasma.
- Lasers used to produce certain chemical reactions.
- Lasers are used in Raman spectroscopy to identify the structure of the molecule.
- Lasers are used in the Michelson- Morley experiment.
- A laser beam is used to conform Doppler shifts in frequency for moving objects.

9. Construction and components of laser